

Vibration Screening Machine



JEL Fix II

► JEL Fix

The JEL Fix is used for protective and oversize grain sieving. Thanks to its low design height and narrow platform, the sieve will find space even in limited production spaces. The JEL Fix can be fitted with a stationary or movable base frame depending on the requirements, or it can be integrated directly into a system without a frame. Thanks to a housing free of dead space and smooth surfaces, the JEL Fix can be cleaned easily and is therefore suited to high standards of hygiene.

► Operation

The sieve's movement is produced using a vibration motor with adjustable imbalance discs. Thanks to the option to adjust this, the screening capacity can be adjusted to be optimal to the appropriate screen feed. Open operation without a cover is made possible by the optional edge attachment.

► Areas of application

Chemicals	Plastics	Pharmaceuticals	Foodstuffs	Similar industries
●	●	●	●	●

► Bulk solids

Grainy	Powdery	Finely powdered	Fatty	Granular
●	●	●	○	●

► Screening applications

Protective screening	Grading	Coarse/Oversize grain screening	Fine screening	Deagglomerating
●	○	●	○	○

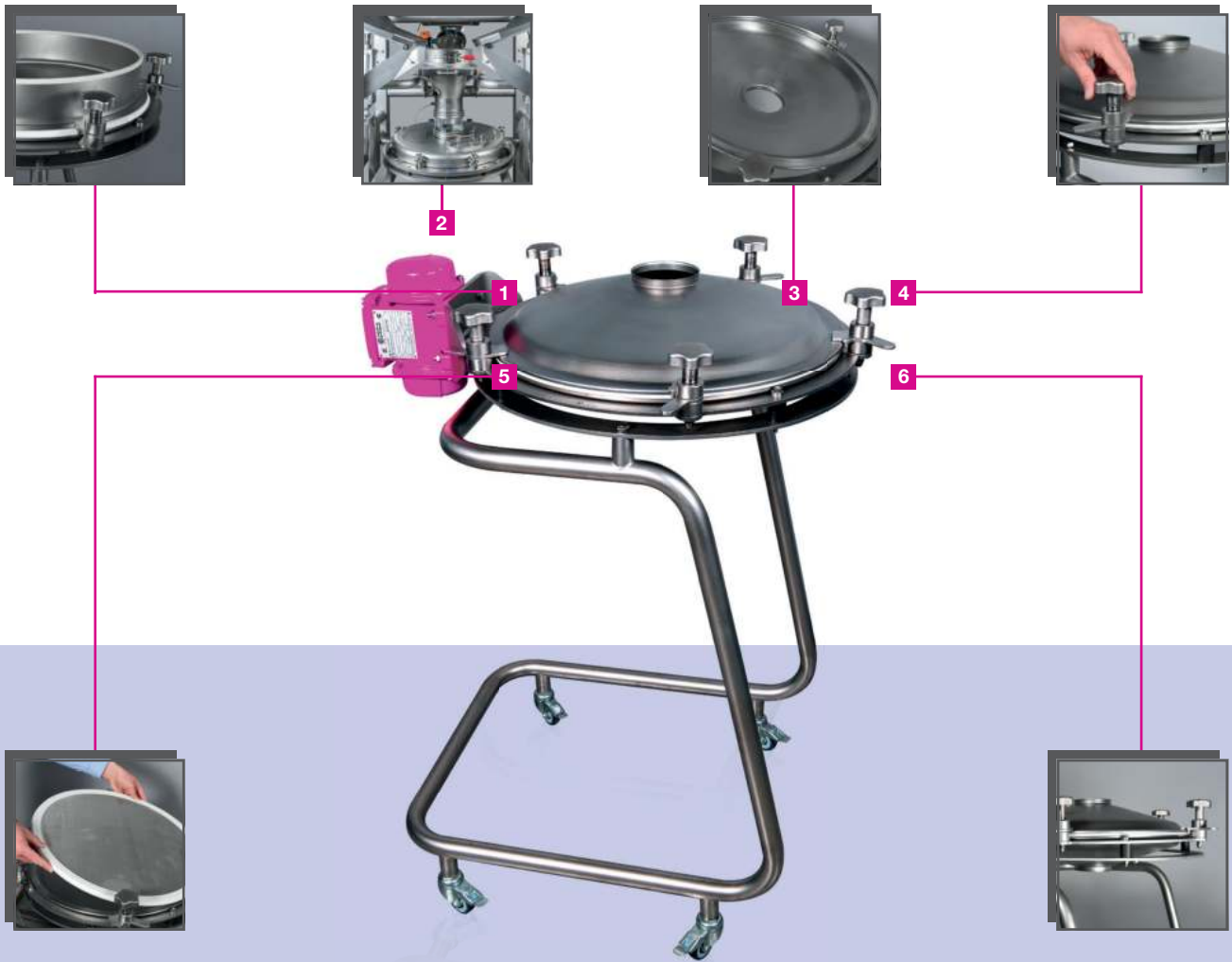

- 1** Edge attachment for operation without cover
- 2** May be integrated into existing and new systems (fig.: gas-tight attachment)
- 3** Easy to clean thanks to smooth surfaces
- 4** Operated without tools
- 5** Sieve insert can be changed easily
- 6** Low design height

VIBRATION SIEVE | JEL Fix II

Vibration Screening Machine

JEL Fix II

► Design

- Materials: Frame made completely of stainless steel, pluggable sealing sections made of silicon or TPE
- A variety of surface finishes and roughnesses
- Dust-tight (gas-tight design on request)
- A variety of sieve-cleaning systems (ball, triangle and ultrasound cleaning)
- Optional: Inspection opening with rubber cover
- Available with or without a base frame (stationary or movable)
- ATEX version available
- Optional edge attachment for open operating without a cover

► Technical details

MACHINE

Type	Screening surface	Weight
JEL-Fix II 30	0.07 m ²	17 kg
JEL-Fix II 50	0.20 m ²	27 kg
JEL-Fix II 80	0.50 m ²	60 kg

VIBRATION MOTORS

Power	Speed	Voltage	Frequency
0.07 kW	3000 min ⁻¹	230/400 V	50 Hz
0.10 kW	3000 min ⁻¹	230/400 V	50 Hz
0.25 kW	3000 min ⁻¹	230/400 V	50 Hz

DIMENSIONS [mm]

Type	ØE*	ØA*	H	H1	H2	B	ØB1	ØB2	ØB3	L	ØSR	UG-Hight**
JEL-Fix II 30	100	100	135	15	213	420	380	350	3 x Ø9	590	317	885
JEL-Fix II 50	100	100	195	45	211	620	580	550	3 x Ø11	810	517	855
JEL-Fix II 80	150	150	270	75	255	975	900	850	3 x Ø11	1130	817	840

* A variety of socket diameters and attachments (e.g. BFM) available on request
 **UG = undercarriage (optional)

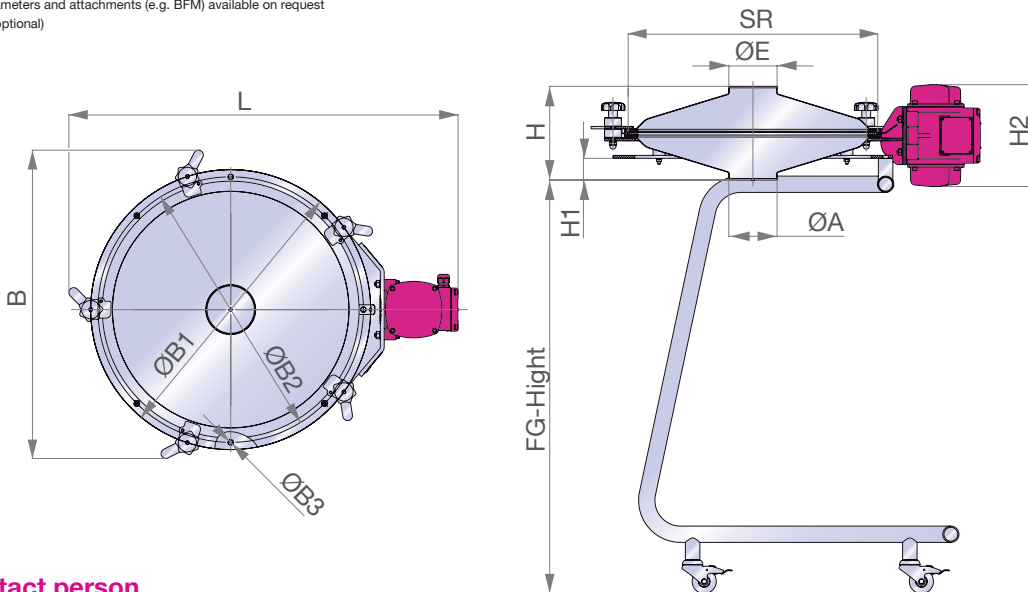

► Your contact person

You have questions or need a non-binding quotation? Our experts are happy to help you!

J. Engelsmann AG

Frankenthaler Str. 137-141
 D-67059 Ludwigshafen

Tel.: +49 (0)621-59002-0
 Fax: +49 (0)621-59002-550

info@engelsmann.de
 www.engelsmann.com



Product page JEL Fix

Convincing facts

- ✓ Flexibly adaptable due to adjustable screening capacity
- ✓ Easily changeable sieve inserts
- ✓ Suited to tight spaces due to its compact design
- ✓ Easy to clean and maintain thanks to easily accessible parts
- ✓ Can be operated comfortably and without tools
- ✓ Low investment costs and quick delivery
- ✓ Can be integrated directly into existing or new systems
- ✓ Hygienic use of the machine due to Hygienic Design Features